

# ROWAN

Solid Brass Directional Fixture



## This compact luminaire offers the flexibility of ground and surface mount all in one box.

Suited for both commercial and residential projects, this durable fixture is constructed of solid red brass offering superior strength and reliability.

Whether you're lighting trees, foliage, architectural pieces or other structures, Rowan's dual-mount feature, combined with its compact size make it an essential fixture in any outdoor lighting design.

As an uplight, using the included stake, Rowan can be positioned close to tree trunks and other structures to emphasize texture and form. Positioned at a distance, this precision fixture is perfect for adding a dramatic effect to dense foliage. Looking for a diminutive uplight to softly illuminate planters on decks and patios? Rowan's compact size is ideal for tucking discreetly into potted plants and small garden beds.

For downlighting large or focused activity areas on patios, lawns, arbors, pools and paths, Rowan mounts easily on trellises, eaves, gazebos and mature trees.

This versatile, directional luminaire uses an MR11 lamp protected by a 5mm (1/8") lens to achieve a soft, ambient light, while providing superior protection from moisture and debris. Rowan also includes 8' of 18/2 waterproof UL-rated wire to stop water intrusion.

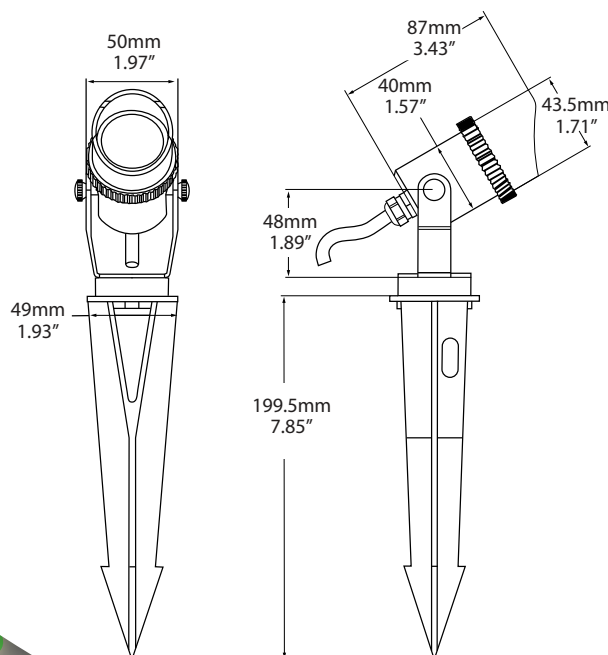

<b>Construction:</b>	Solid Cast Brass
<b>Dimensions:</b>	1.97" x 5.32"
<b>Lamp:</b>	LED MR11*
<b>Wattage:</b>	Maximum 20 Watts
<b>Lens:</b>	1/8" Flat Tempered Glass
<b>Socket:</b>	Pre-greased Beryllium Copper
<b>Wire:</b>	8' 18/2 UL-Rated Wire
<b>Weight:</b>	1.5 lb
<b>Includes:</b>	7" Plastic Stake
<b>Voltage:</b>	12V

\*Lamp not included